



You have selected a reliable, high-quality dispensing system from Nordson EFD, the world leader in fluid dispensing. The 797PCP Series progressive cavity pump is designed specifically for industrial dispensing and will provide you with years of trouble-free, productive service.

This manual will help you maximize the usefulness of your 797PCP.

Please spend a few minutes to become familiar with the controls and features. Follow our recommended testing procedures. Review the helpful information we have included, which is based on more than 50 years of industrial dispensing experience.

Most questions you will have are answered in this manual. However, if you need assistance, please do not hesitate to contact EFD or your authorized EFD distributor. Detailed contact information is provided on the last page of this document.

## The Nordson EFD Pledge

Thank You!

You have just purchased the world's finest precision dispensing equipment.

I want you to know that all of us at Nordson EFD value your business and will do everything in our power to make you a satisfied customer.

If at any time you are not fully satisfied with our equipment or the support provided by your Nordson EFD Product Application Specialist, please contact me personally at 800.556.3484 (US), 401.431.7000 (outside US), or [Srini.Subramanian@nordsonefd.com](mailto:Srini.Subramanian@nordsonefd.com).

I guarantee that we will resolve any problems to your satisfaction.

Thanks again for choosing Nordson EFD.

*Srini Subramanian*  
Srini Subramanian, General Manager

# Contents

Contents .....	3
Introduction .....	4
Configuration Options.....	4
How the Pump Operates .....	5
How to Control the Pump.....	5
Specifications.....	6
Operating Features.....	7
Installation .....	8
Unpack the System Components.....	8
Assemble the Pump.....	9
Mount the Pump .....	10
Connect the Fluid Supply .....	11
Bleed the Pump .....	12
Calibrate the Pump.....	12
Purge Through the Outlet Adapter (No Tip).....	13
Install the Tip .....	14
Purge Through the Tip.....	15
Example System Layout: 7197PCP-DIN Controller and 797PCP .....	17
Example System Layout: ValveMate 7197PCP Controller and 797PCP .....	18
Service.....	19
Pump Disassembly .....	19
Pump Assembly.....	22
Pump Storage .....	24
Part Numbers .....	25
797PCPs.....	25
Pump Motor Cable .....	25
Accessories .....	26
Mounting Bracket .....	26
Fluid Supply.....	26
Fluid Inlet Fittings.....	26
Replacement Parts.....	28
Troubleshooting .....	29

## Introduction

This manual provide specifications, installation, service, part numbers, and troubleshooting information for 797PCP Series progressive cavity pumps. The 797PCP dispenses an exact, repeatable volume of fluid as small as 0.01 mL per revolution for applications that require extremely consistent dispensing control.

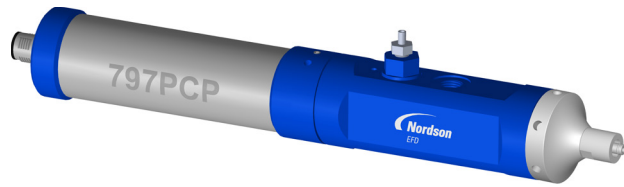

Features of the 797PCP:

- Viscosity-independent
- Low pulsing and shearing operation
- High dispensing accuracy
- High repeatability
- Suck-back operation to prevent drooling
- Conditionally appropriate for highly abrasive fluids\*

Typical applications include:

- Coating of printed circuit boards
- Bead dispensing
- Underfilling
- Glue dispensing
- Filling compound dispensing
- Under certain conditions, highly viscous abrasive and corrosive fluid dispensing\*

**NOTE:** Due to the risk of contamination, sealants such as hemp or putty are not recommended.

\*If you will be dispensing highly abrasive or corrosive fluids, refer to “797PCP Selection for Highly Abrasive / Filled Materials” on page 25 for correct pump selection. While 797PCPs are capable of dispensing these fluids, there is a risk of equipment damage if the dispensing process is not properly set up and managed.

## Configuration Options

Pumps come in three sizes:

- 0.01 mL/rev
- 0.05 mL/rev
- 0.15 mL/rev

## How the Pump Operates

The core components of the 797PCP are the metal rotor and rubber stator, which form a perfectly sealed metering chamber. As the chamber rotates, fluid moves from one sealed cavity to the next, allowing for continuous volumetric dispensing independent of fluid viscosity or changes in viscosity over time. Output is controlled by a 24 VDC motor, allowing the pump to dispense very precise amounts of fluid.

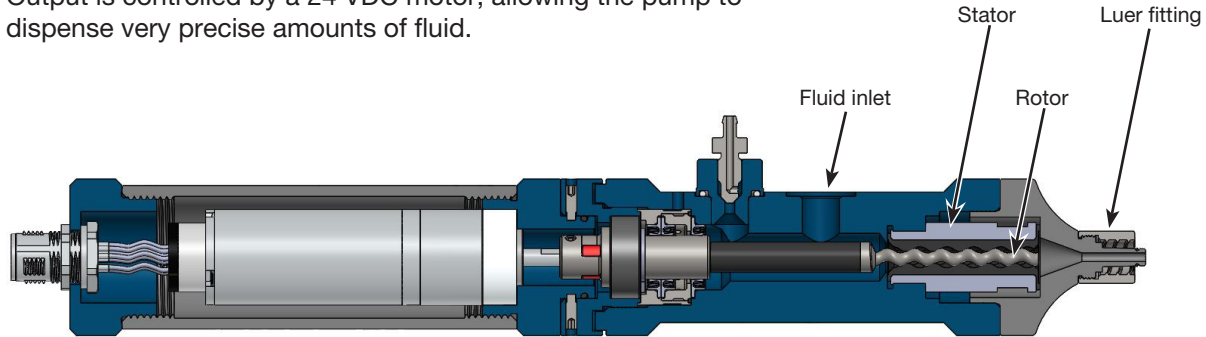

## How to Control the Pump

For best results, use Nordson EFD 797PCPs with fully integrated 7197PCP controllers, which provide multiple programming modes — Line, Volume, Weight, or Timed — to meet the unique needs of your application. Advanced features, such as the ability to change the rotor speed when dispensing a line around corners, deliver a high level of process control.



*ValveMate 7197PCP Controller provides desktop control of the pumps*



*7197PCP-DIN Controller allows Internet-based control of the pumps*

## Specifications

**NOTE:** Specifications and technical details are subject to change without prior notification.

Item / Output	797PCP-0.01 mL/rev	797PCP-0.05 mL/rev	797PCP-0.15 mL/rev
Size	261.4L x 36.0DIA mm (10.29L x 1.42DIA")	261.4L x 36.0DIA mm (10.29L x 1.42DIA")	297.9L x 36.0DIA mm (11.73L x 1.42DIA")
Weight	550.0 g (1.2 lb)	550.0 g (1.2 lb)	620.0 g (1.4 lb)
Rotor speed	10–150 RPM (depending on maximum motor speed)		
Motor	24 VDC incremental encoder, planetary gears		
Starting torque	0.22 N•m (1.95 in.-lb)	0.24 N•m (2.12 in.-lb)	0.73 N•m (6.46 in.-lb)
Maximum motor speed (based on fluid viscosity)*	1–800 mPa s: Up to 100% of motor speed 800–10,000 mPa s: 90% of maximum motor speed 10,000–25,000 mPa s: 70% of maximum motor speed 25,000–50,000 mPa s: 50% of maximum motor speed 50,000–150,000 mPa s: 25% of maximum motor speed		
Flow rate	0.13–1.95 mL/min	0.59–8.85 mL/min	1.63–24.50 mL/min
Minimum dispensing volume	0.002 mL	0.008 mL	0.01 mL
Dispensing volume per revolution	0.009 mL	0.047 mL	0.139 mL
Repeatability	±1%		
Maximum fluid inlet pressure	0–6 bar (0–87 psi)		
Maximum generated fluid outlet pressure	16–20 bar (232–290 psi)		
Fluid inlet	1/8 NPT		
Fluid outlet	Luer fitting		
Mounting	M4		
Fluid chamber	Anodized aluminum		
Rotor	300 stainless steel		
Stator	FFKM (perfluoroelastomer)		
Operating temperature**	10–40° C (50–104° F)		
Fluid temperature	10–40° C (50–104° F)		
Storage conditions	10–40° C (50–104° F), dry and dust-free; pumps must be stored unassembled		
Approvals	CE, WEEE		

All stainless steel parts are passivated.

\*Maximum motor speed values are based on fluids without fillers. The pump is self-priming when certain conditions are met. However, higher viscosity fluids must first be introduced into the pump (pre-pressure). Do not exceed the pre-pressure values stated in the Technical Data Sheet for the fluid. These values can change depending on speed and viscosity. The values provided are guidelines only; maximum speed depends on the application and the environmental conditions. The maximum permitted speed is crucial for the service life or wear of the pump. The inlet pressure must be selected within the stated limits so that continuous filling of the pump is guaranteed.

\*\*Because the viscosity of fluid can change when the temperature changes, the minimum and maximum operating temperature depends on the composition of the O-rings / seals.

### WEEE Directive



This equipment is regulated by the European Union under WEEE Directive (2012/19/EU). Refer to [www.nordsonefd.com/WEEE](http://www.nordsonefd.com/WEEE) for information about how to properly dispose of this equipment.

# Operating Features

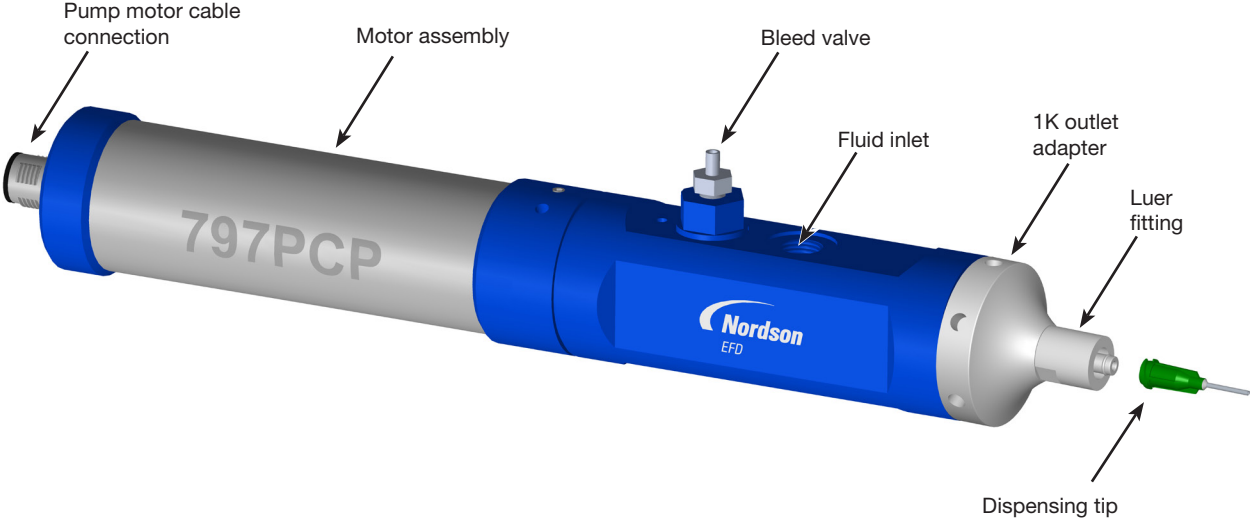

## Installation

Prior to installing the pump, read the associated reservoir and pump controller operating manuals to become familiar with the operation of all components of the dispensing system.

### Unpack the System Components

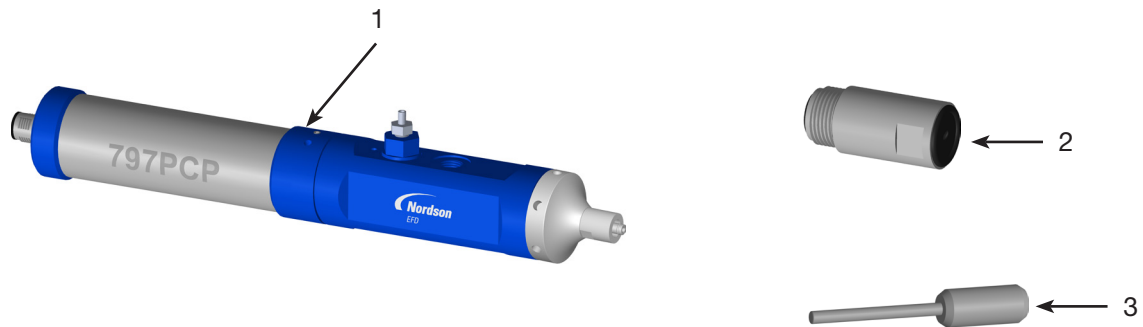

- 1 797PCP
- 2 Stator
- 3 Coupling anti-rotation pin



Ordered separately (not shown)  
Pump motor cable  
Dispensing tip

## Installation (continued)

### Assemble the Pump

To prevent damage, the stator is shipped separately. Follow this procedure to install the stator.

You will need the following items:

- Spanner wrench 
- Coupling anti-rotation pin (shipped with the pump) 
- 14 mm low-profile open-end wrench (for stator installation or removal)

#### CAUTION

Risk of equipment damage. Do not dry-assemble the rotor and stator. Excessive friction of dry components can damage the pump.

#### CAUTION

Do not use water with a 797PCP. Doing so can damage the lubricated shaft and bearings.

1. Use a spanner wrench to remove the outlet adapter. 

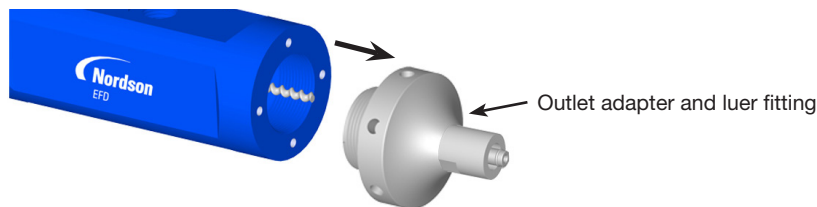

2. Wet the rotor and stator with the dispensing fluid (or any appropriate lubricant that is compatible with the dispensing fluid).

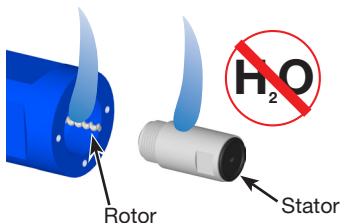

3. Insert the coupling anti-rotation pin into the housing to secure the coupling. If needed, carefully turn the stator / robot assembly until you feel the pin drop in between the tabs of the gear ring.

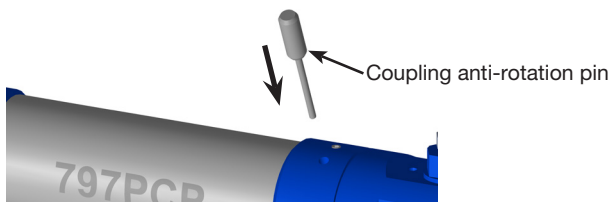

## Installation (continued)

- Use a 14 mm low profile wrench to carefully screw the stator clockwise first onto the rotor, and then into the threads inside the pump housing.

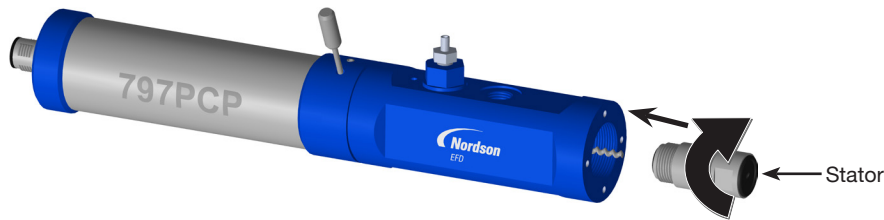

- Thread the outlet adapter onto the pump body and hand tighten. Use the spanner wrench for final tightening.

**NOTE:** Do not install the dispensing tip at this time.

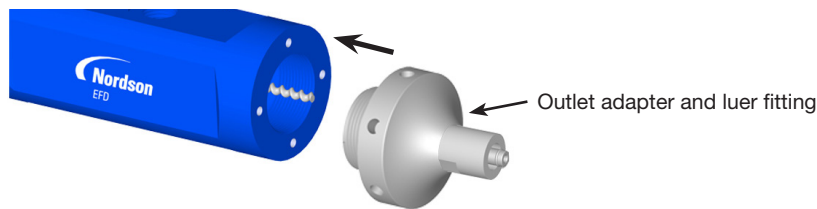

- Continue to “Mount the Pump” below.

## Mount the Pump

You will need the following items:

- M3 hex wrench 
- Pump mounting bracket (refer to “Accessories” on page 26)

Determine the pump orientation and rotation that will be suitable for your application and then mount the pump on the production line. The 797PCP can be mounted in any orientation (vertical, diagonal, horizontal, etc.).

**NOTE:** If the pump is being incorporated into an automated dispensing system, ensure that the pump is mounted securely on the Z axis such that it cannot loosen during dispensing. The mounting method should also allow accurate adjustment of the distance between the dispensing tip and the workpiece using a device such as a laser or touch-type height sensor.

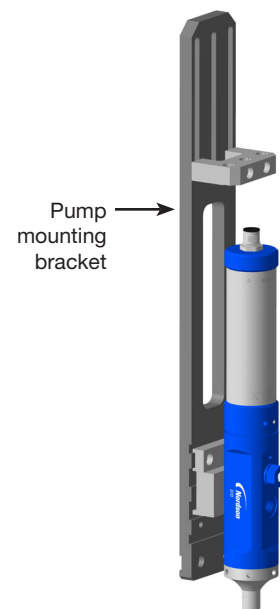

## Installation (continued)

### Connect the Fluid Supply

You will need the following items:

- 8 mm low-profile open-end wrench (for the bleed valve hex nut)
- Fluid supply components and fluid inlet fitting (refer to “Accessories” on page 26)
- Dispensing fluid (or compatible cleaning fluid)

#### CAUTION

Risk of equipment damage. Do not over-tighten fittings. Doing so can damage the anodized aluminum pump housing.

#### CAUTION

Do not use water with a 797PCP. Doing so can damage the lubricated shaft and bearings.

1. Connect the dispensing fluid supply to the fluid inlet. **Do not pressurize the fluid supply at this time.**

#### NOTES:

- Nordson EFD recommends using a compatible cleaning fluid for initial startup.
- Several fluid fitting options are available. Refer to “Accessories” on page 26.

2. Install any system components other than the 797PCP that will comprise the complete dispensing system, including the pump controller. Refer to the following system setup examples:

- “Example System Layout: 7197PCP-DIN Controller and 797PCP” on page 17
- “Example System Layout: ValveMate 7197PCP Controller and 797PCP” on page 18

**NOTE:** For example, if you are using a fluid reservoir, position and install all the fluid reservoir components. For all ancillary components, such as the pump controller, refer to the quick start guide and / or operating manual provided with those components for installation and setup instructions.

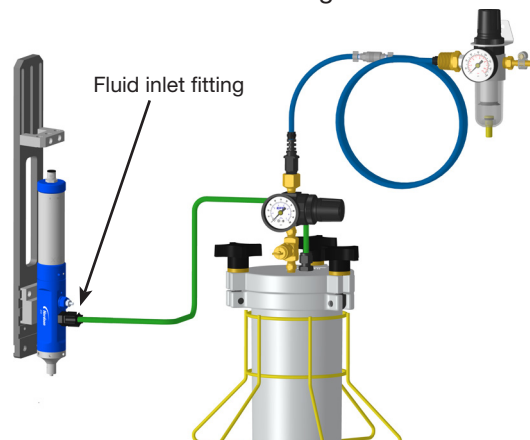

#### CAUTION

Risk of equipment damage. Bleed the 797PCP and then purge with the dispensing material before placing it into operation. Failure to bleed and purge before initial startup will damage the pump.

3. Continue to “Bleed the Pump” on page 12.

## Installation (continued)

### Bleed the Pump

#### WARNING

Risk of personal injury. Ensure that the fluid supply pressure is set very low. Higher pressures can cause low viscosity fluids to spray from the pump.

1. Set the fluid pressure to approx 0.3 bar (5 psi), depending on the viscosity of the fluid.
2. Place a towel or container under the pump bleed valve and then use an 8 mm low-profile open-end wrench to turn the bleed valve hex screw counterclockwise (about 1/2 turn or less).
3. Allow material to seep from the bleed valve until it is free of trapped air (no air bubbles).
4. Close the bleed valve.
5. Continue to “Calibrate the Pump” below.

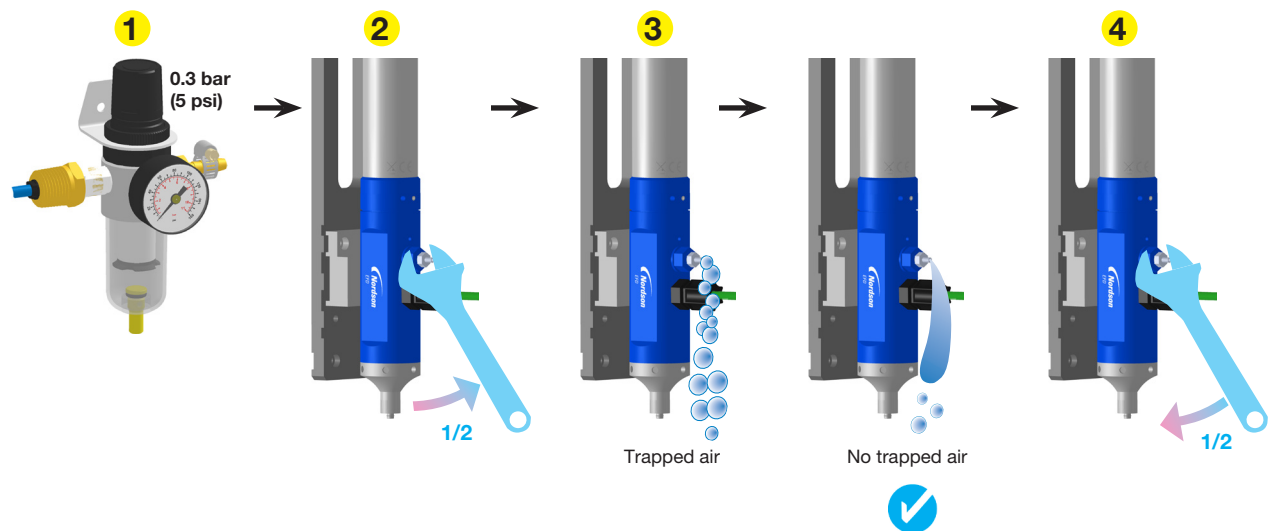

### Calibrate the Pump

Before a pump is purged for the first time, it must be calibrated to the controller.

**Go to the controller manual and follow the procedure for initial startup and calibration. Return here and then continue to “Purge Through the Outlet Adapter (No Tip)” on page 13.**

## Installation (continued)

### Purge Through the Outlet Adapter (No Tip)

Before purging the pump through the tip, first purge the pump without the tip installed.

#### CAUTION



Risk of equipment damage. **Do not operate a 797PCP without fluid.** Excessive friction of dry components can damage the pump.

1. Ensure that the dispensing tip is not installed.
2. Ensure that the bleed valve is closed (turned fully clockwise).
3. Place a paper towel or container under the 797PCP outlet adapter to catch fluid.

#### WARNING

Risk of personal injury. Ensure that the fluid supply pressure is set very low. Higher pressures can cause low viscosity fluids to spray from the pump.

4. Ensure that the fluid supply pressure is set very low.
5. Refer to the table below to purge the pump based on the type of controller in your system.

Your Controller	Purge Procedure
 <p>7197PCP-DIN</p>	<ol style="list-style-type: none"> <li>a. Open the PURGE screen.</li> <li>b. Select the ENABLE PURGE radio button.</li> <li>c. Trigger the purge initiate circuit.</li> </ol> <p><b>NOTE:</b> The default purge RPM is 10. To change the RPM, refer to the procedure for adjusting the purge RPM in the controller manual.</p>
 <p>ValveMate 7197PCP</p>	<ol style="list-style-type: none"> <li>a. Go to PROGRAMS &gt; LINE.</li> </ol> <p><b>NOTE:</b> The Line program will be used to purge the pump.</p> <ol style="list-style-type: none"> <li>b. Enter the following settings:           <ul style="list-style-type: none"> <li>• RPM = 10</li> <li>• Reverse % = 1</li> <li>• Correction Factor = 1.03</li> <li>• Analog Off</li> </ul> </li> </ol> <p><b>NOTE:</b> The default purge RPM is 10. To change the RPM, refer to the procedure for adjusting the purge RPM in the controller manual.</p> <ol style="list-style-type: none"> <li>c. Select the ENABLE LINE PROGRAM radio button.</li> <li>d. Press the foot pedal.</li> </ol>

## Installation (continued)

### Purge Through the Outlet Adapter (No Tip) (continued)

6. Allow fluid to flow from the outlet adapter until it is completely free of trapped air.
7. Stop the purge by removing the purge initiate signal (7197PCP-DIN) or by releasing the foot pedal (ValveMate 7197PCP).
8. Continue to “Install the Tip” below.



### Install the Tip

1. Install the dispensing tip and ensure that it is filled with fluid.

**NOTES:**

- For some applications, you can pre-fill the tip by installing it on a filled syringe barrel, then transferring it to the pump; alternatively, you can run the pump until the tip fills with fluid.
- For thick, higher viscosity fluids, Nordson EFD recommends SmoothFlow™ tapered tips.

2. Continue to “Purge Through the Tip” on page 15.

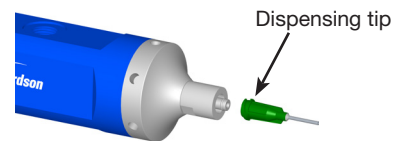

## Installation (continued)

### Purge Through the Tip

797PCPs should be purged as follows:

- After installation and before initial startup (first use)
- As needed with a cleaning material (depending on the dispensing fluid)
- Before daily routine operation (depending on the dispensing fluid)

Purging eliminates trapped air and ensures that the pumps are completely filled with fluid before dispensing.

#### CAUTION



Risk of equipment damage. **Do not operate 797PCPs without fluid.** Excessive friction of dry components can damage the pumps.

1. Ensure that the bleed valve is closed (turned fully clockwise).
2. Place a paper towel or container under the tip.

#### WARNING

Risk of personal injury. Ensure that the fluid supply pressure is set very low. Higher pressures can cause low viscosity fluids to spray from the pump.

3. Ensure that the fluid supply pressure is set very low.
4. Purge a pump based on the type of controller in your system:

Your Controller	Purge Procedure
  7197PCP-DIN	<ol style="list-style-type: none"> <li>a. Open the PURGE screen.</li> <li>b. Select the ENABLE PURGE radio button.</li> <li>c. Trigger the purge initiate circuit.</li> </ol> <p><b>NOTE:</b> The default purge RPM is 10. To change the RPM, refer to the procedure for adjusting the purge RPM in the controller manual.</p>
 ValveMate 7197PCP	<ol style="list-style-type: none"> <li>a. Go to PROGRAMS &gt; LINE.</li> </ol> <p><b>NOTE:</b> The Line program will be used to purge the pump.</p> <ol style="list-style-type: none"> <li>b. Enter the following settings:             <ul style="list-style-type: none"> <li>• RPM = 10</li> <li>• Reverse % = 1</li> <li>• Correction Factor = 1.03</li> <li>• Analog Off</li> </ul> </li> </ol> <p><b>NOTE:</b> The default purge RPM is 10. To change the RPM, refer to the procedure for adjusting the purge RPM in the controller manual.</p> <ol style="list-style-type: none"> <li>c. Select the ENABLE LINE PROGRAM radio button.</li> <li>d. Press the foot pedal.</li> </ol>

## Installation (continued)

### Purge Through the Tip (continued)

5. Allow fluid to flow from the tip until it is completely free of trapped air.
6. Stop the purge by removing the purge initiate signal (7197PCP-DIN) or by releasing the foot pedal (ValveMate 7197PCP).
7. If applicable, change the fluid supply to the desired material.
8. Set the fluid pressure to the required application setting.

**Refer to the controller manual for system setup and testing and for operating instructions.**

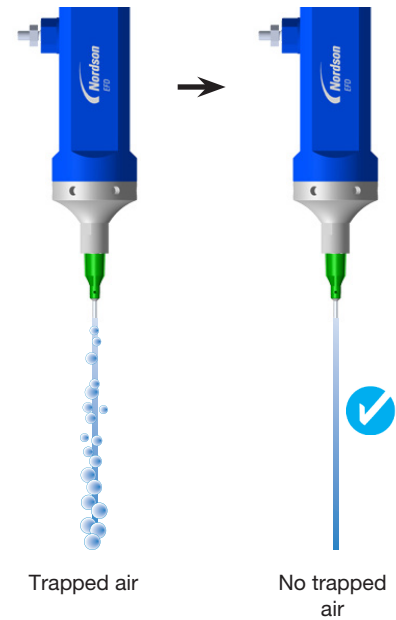

# Installation (continued)

## Example System Layout: 7197PCP-DIN Controller and 797PCP

For controller setup and system startup and testing, refer to the controller operating manual.

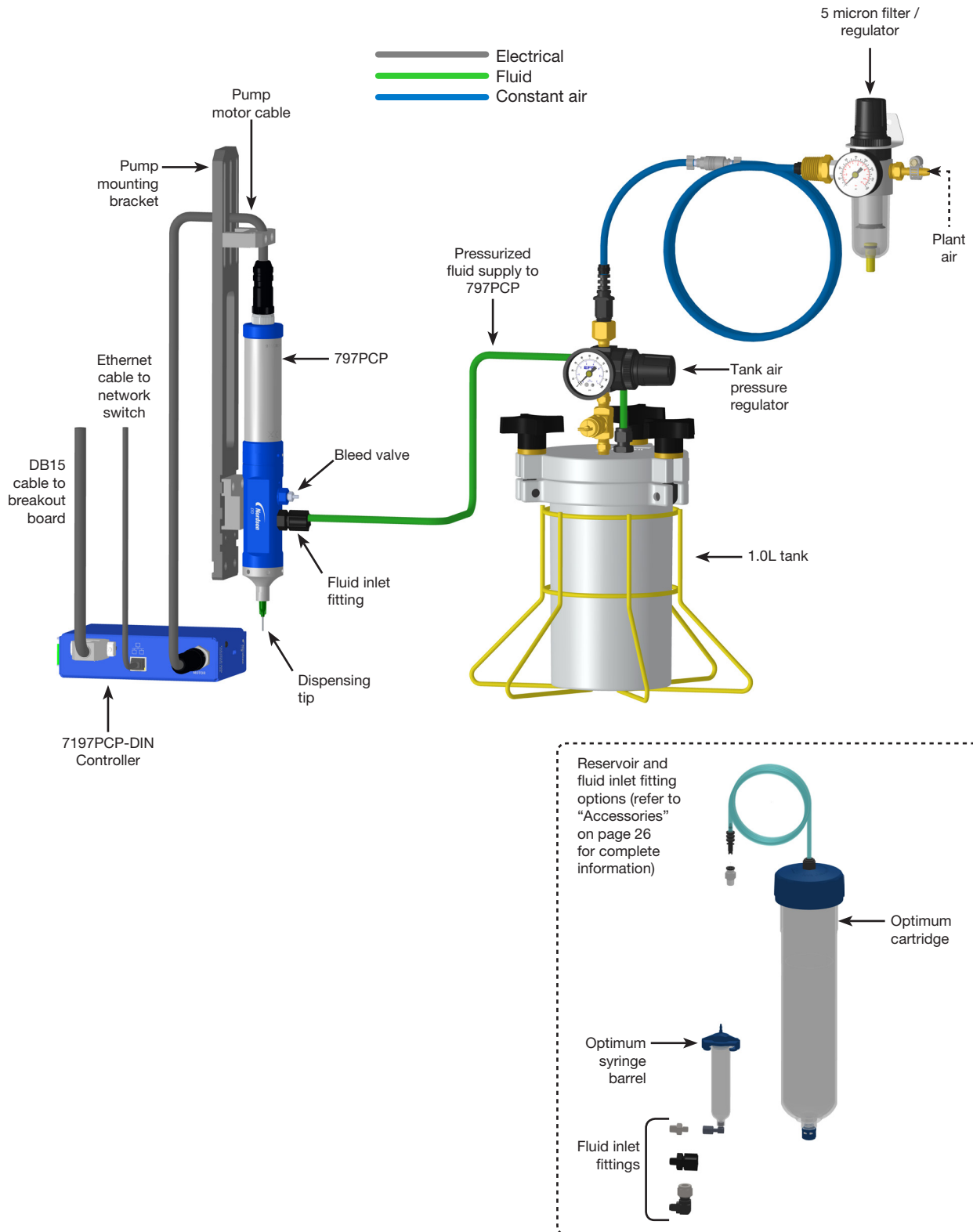

# Installation (continued)

## Example System Layout: ValveMate 7197PCP Controller and 797PCP

For controller setup and system startup and testing, refer to the controller operating manual.

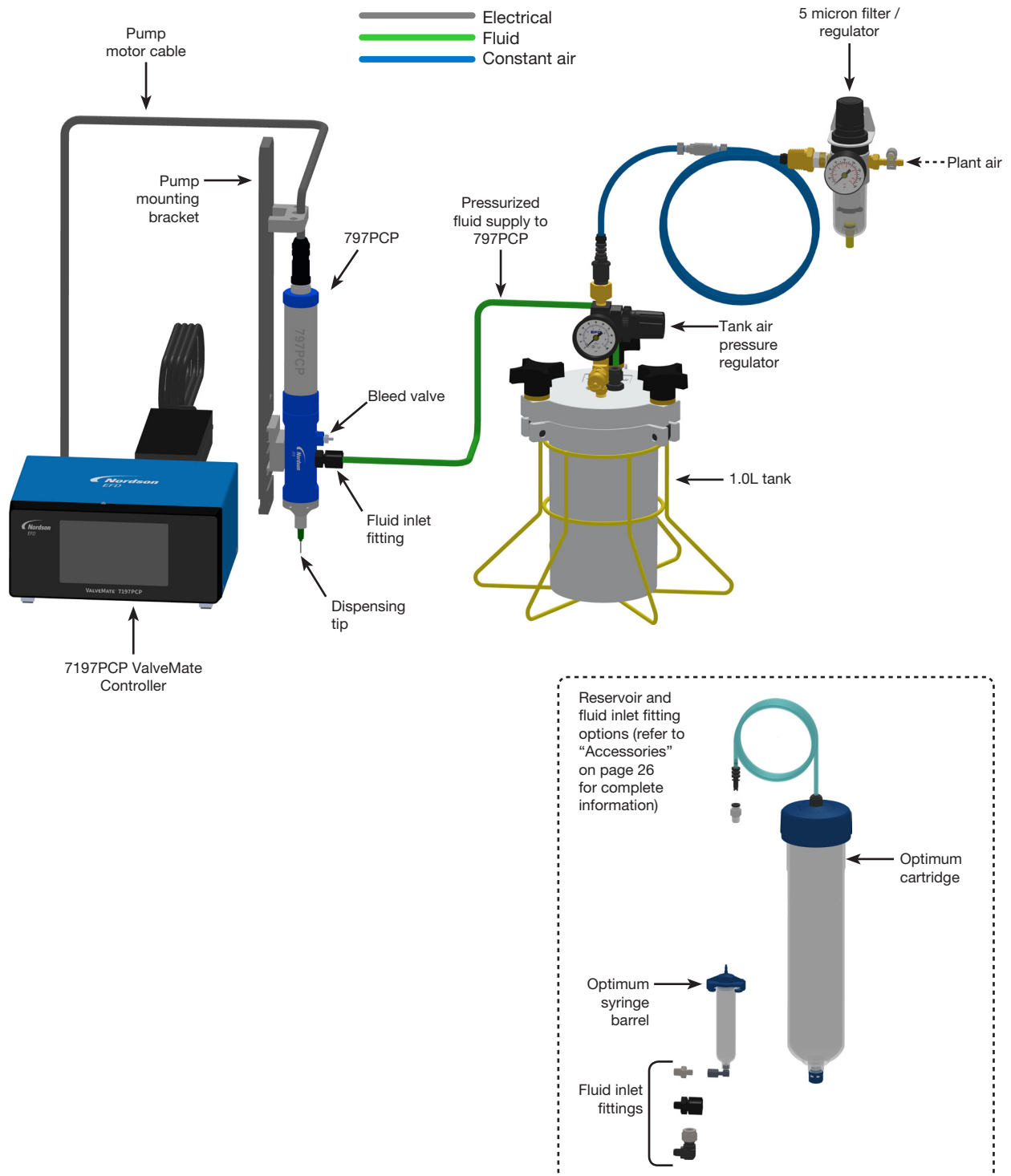

## Service



797PCPs are largely maintenance-free. However, some operating conditions may subject the gaskets, bearings, stator, and rotor to wear, requiring them to be replaced at regular intervals. Regularly review your performance data to determine appropriate service intervals. Any time the pump is serviced, also perform the following actions:

- Check all fastening screws and connections to ensure they are securely tightened; re-tighten as needed.
- Check the coupling (elastomer) for wear.
- Check the leak resistance of the pump, especially the shaft seals.

## Pump Disassembly

**NOTE:** During disassembly, observe the position of the pump components in relation to each other. Nordson EFD recommends marking the position of the components and numbering them consecutively.

### Required Tools

- 11 mm low-profile open-end wrench (for luer fitting removal or installation)
- Spanner wrench 
- Coupling anti-rotation pin (shipped with the pump) 
- 14 mm low-profile open-end wrench (for stator removal or installation)
- M3 hex wrench 

### Preparation for Service

1. Shut off the air supply to the system.
2. Stop the fluid supply to the pump and disconnect fluid supply tubing.
3. Disconnect the pump motor cable from the controller.
4. Remove the pump from the pump bracket.
5. Remove the dispensing tip.

### Remove the Luer Fitting and Outlet Adapter

1. Use an 11 mm low-profile open-end wrench to remove the luer fitting.
2. Use a spanner wrench to remove the outlet adapter. 

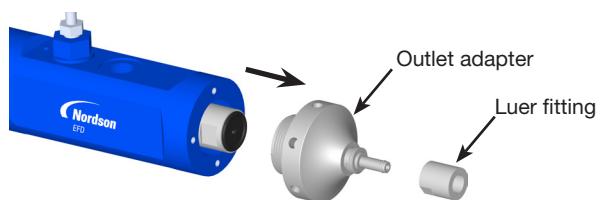

## Pump Disassembly (continued)

### Remove the Stator

1. Insert the coupling anti-rotation pin into the housing to secure the coupling. If needed, carefully turn the stator / robot assembly until you feel the pin drop in between the tabs of the gear ring.

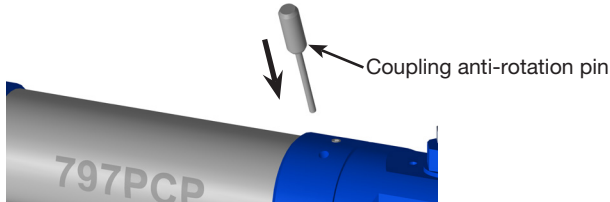

2. After the coupling is secured, use a 14 mm low-profile open-end wrench to carefully turn the stator counterclockwise to remove it.

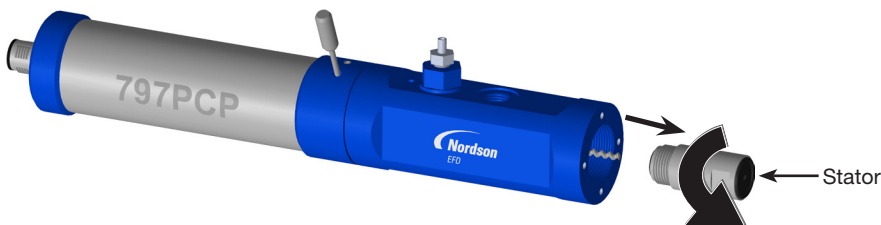

3. If the pump will be returned to normal operation directly after service, continue to “Remove the Fluid Body” on page 21 to complete the pump disassembly.

If the pump will be stored, then disassembly is complete. Refer to “Pump Storage” on page 24 for details.

## Pump Disassembly (continued)

### Remove the Fluid Body

1. Use an M3 hex wrench to loosen the dog head set screws located in the mounting flange, then remove motor assembly.

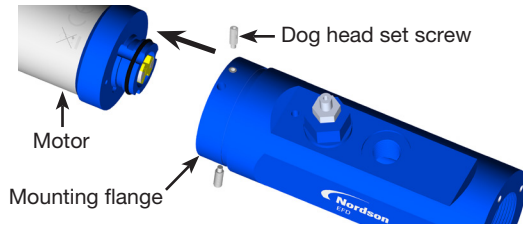

2. Unscrew and remove the mounting flange.

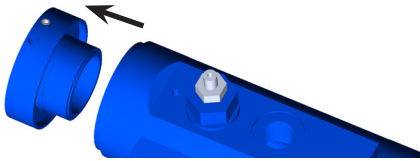

3. Remove the seal bearing and rotor assemblies.

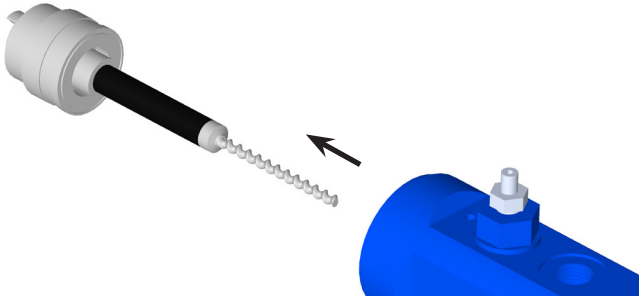

4. Carefully isolate the seal bearing assembly from the rotor.
5. Disassemble the seal bearing assembly and inspect the components. Obtain replacements for any damaged components.

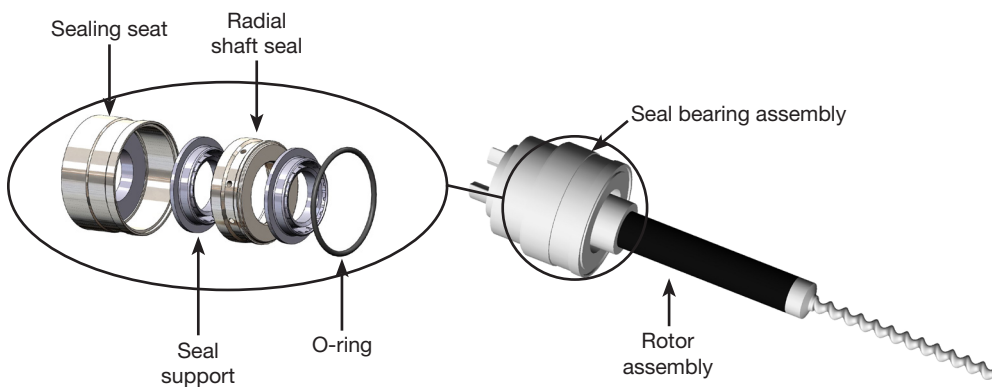

## Pump Assembly

During assembly:

- Inspect O-rings and seals for damage and replace with new ones as needed.
- Always replace PTFE gaskets.
- Completely remove any sealant residue.

### Reassemble the Fluid Body

1. Assemble the seal bearing assembly and install it on the rotor assembly.

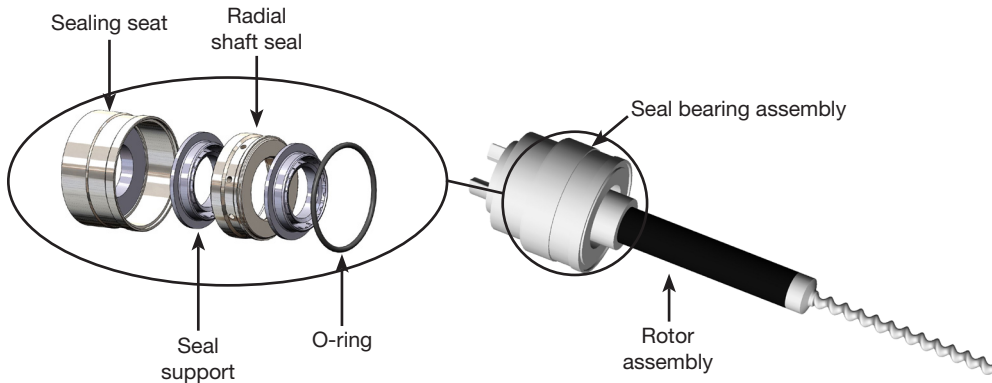

2. Insert the seal bearing and rotor assemblies in the pump housing.

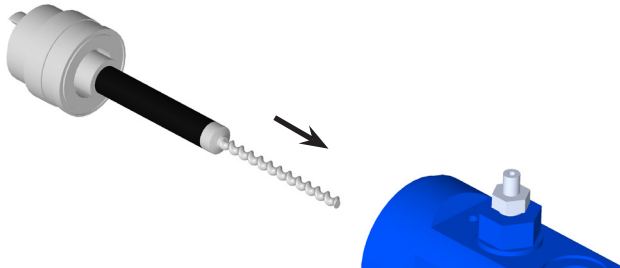

3. Reinstall the mounting flange.

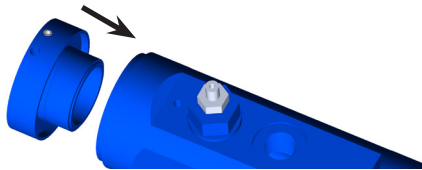

4. Use an M3 hex wrench to install the motor assembly using the two dog head set screws removed previously.

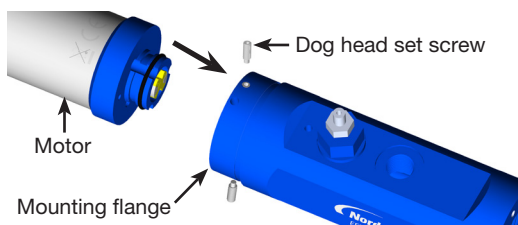

## Pump Assembly (continued)

### Install the Stator

1. Insert the coupling anti-rotation pin into the housing to secure the coupling. If needed, carefully turn the stator / robot assembly until you feel the pin drop in between the tabs of the gear ring.

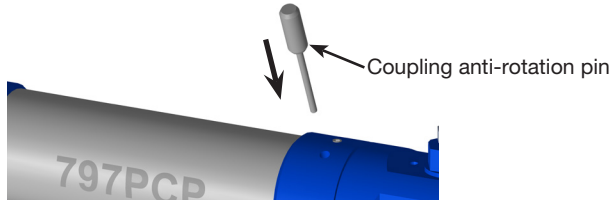

2. Carefully screw the stator clockwise first onto the rotor, and then into the threads inside the pump housing, until it is fully tightened in the fluid body housing. Avoid over-torquing.

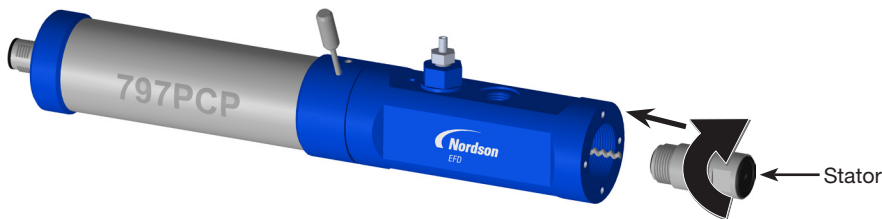

3. Thread the outlet adapter onto the pump body and use the spanner wrench to tighten.
4. Use an 11 mm low-profile open-end wrench to reinstall the luer fitting.

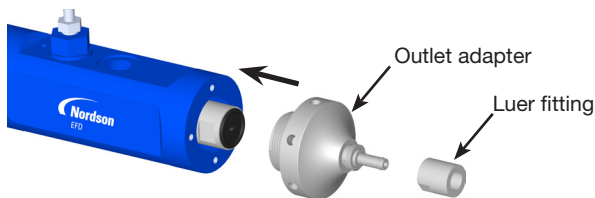

5. Install the dispensing tip.
6. After every rotor or stator change, calibrate the system. Refer to the controller manual for the calibration procedure.

Pump assembly is now complete. Reinstall the pump on the production line and restore the system to normal operation.

## Pump Storage

For long periods of downtime or for storage, remove the stator from the rotor to prevent rotor deformation. Refer to the following procedures to remove the stator:

- “Remove the Luer Fitting and Outlet Adapter” on page 19
- “Remove the Stator” on page 20

To restore the pumps to normal operation, refer to “Assemble the Pump” on page 9.

Ensure that the following conditions are met for pump storage:

- The stator is removed from the rotor.
- The maximum ambient storage temperature is 25° C (77° F); the relative humidity maximum is 80%.
- Pump and motor assemblies are stored in enclosed rooms.
- Pumps are protected against sunlight and UV light.
- No aggressive or corrosive materials or agents are stored nearby.

## Part Numbers

The 797PCP and pump motor cable are ordered separately.

### 797PCPs

All 797PCPs include the coupling anti-rotation tool.

Item	Part #	Description
	7364197	797PCP-0.01 pump, 0.01 mL per revolution, 0.13–1.95 mL per minute flow rate
	7364198	797PCP-0.05 pump, 0.05 mL per revolution, 0.59–8.85 mL per minute flow rate
	7364199	797PCP-0.15 pump, 0.15 mL per revolution, 1.63–24.50 mL per minute flow rate

### 797PCP Selection for Highly Abrasive / Filled Materials

Although 797PCPs can be used to dispense particle-filled materials, doing so will cause premature wear to the rotor and stator, requiring rotor / stator replacement. When using a 797PCP to dispense particle-filled materials, first consult with your Nordson EFD representative. Proper pump selection will be based on the percentage of particles in the fluid, the type and size of the particles, and the shape (sharp, soft and round, or hard and abrasive).

#### CAUTION

Risk of equipment damage. The dispensing of highly abrasive / filled materials or pastes causes premature rotor / stator damage.

### Pump Motor Cable

Item	Part #	Description
	7364280	Pump motor cable, 5 m (16.4 ft)

## Accessories





### Mounting Bracket

Item	Part #	Description
	7364423	797PCP pump mounting bracket, PROPlus / PRO Series and GV Series robots

### Fluid Supply

Many fluid supply options are available. Contact your Nordson EFD application specialist for assistance. For a complete list of Optimum™ components, see [www.nordsonefd.com/Optimum](http://www.nordsonefd.com/Optimum).

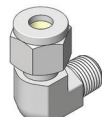





### Fluid Inlet Fittings

Item	Part #	Description	Material	Color
	7364741	Fitting: 1/8 NPT x M8 reducer <b>NOTE:</b> Use with syringe barrel adapter P/Ns 7825120 and 7825121.	Stainless steel	Silver
	7825120	Steel luer lock adapter for syringe barrels <b>NOTE:</b> Use with fitting P/N 7364741.	Stainless steel	Silver
	7825121	Plastic luer lock adapter for syringe barrels <b>NOTE:</b> Use with fitting P/N 7364741.	Plastic (PEEK)	Natural
	7014732	Fitting: 1/8 NPT X 3/8 compression elbow, stainless steel	Stainless steel	Silver
	7021462	Fitting: 1/8 NPT X 1/8 barb	Nylon	Black
	7021460	Fitting: 1/8 NPT X 1/8 barb	Polypropylene	Clear
	7021466	Fitting: 1/8 NPT X 1/8 barb elbow	Nylon	Black

*Continued on next page*

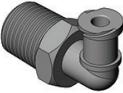
## Accessories (continued)

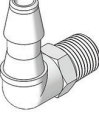
### Fluid Inlet Fittings (continued)

Item	Part #	Description	Material	Color
	7021532	Fitting: 1/8 NPT X 1/4 compression	Polypropylene	Black
	7007038	Fitting: 1/8 NPT X 3/8 compression	Polypropylene	Black
	7021499	Fitting: 1/8 NPT X 1/4 compression elbow	Polypropylene	Black
	7020903	Fitting: Barrel to 1/8 NPT elbow	Polypropylene	Black
	7021464	Elbow fitting: 1/8 NPT X 1/8 barb	Polypropylene	Clear
	7021496	Elbow fitting: 1/8 NPT X 3/8 barb	Nylon	Black
	7021494	Elbow fitting: 1/8 NPT X 3/8 barb	Polypropylene	Natural
	7020136	Fitting: 1/8 NPT X 3/8 compression elbow	Nylon	Black

# Replacement Parts

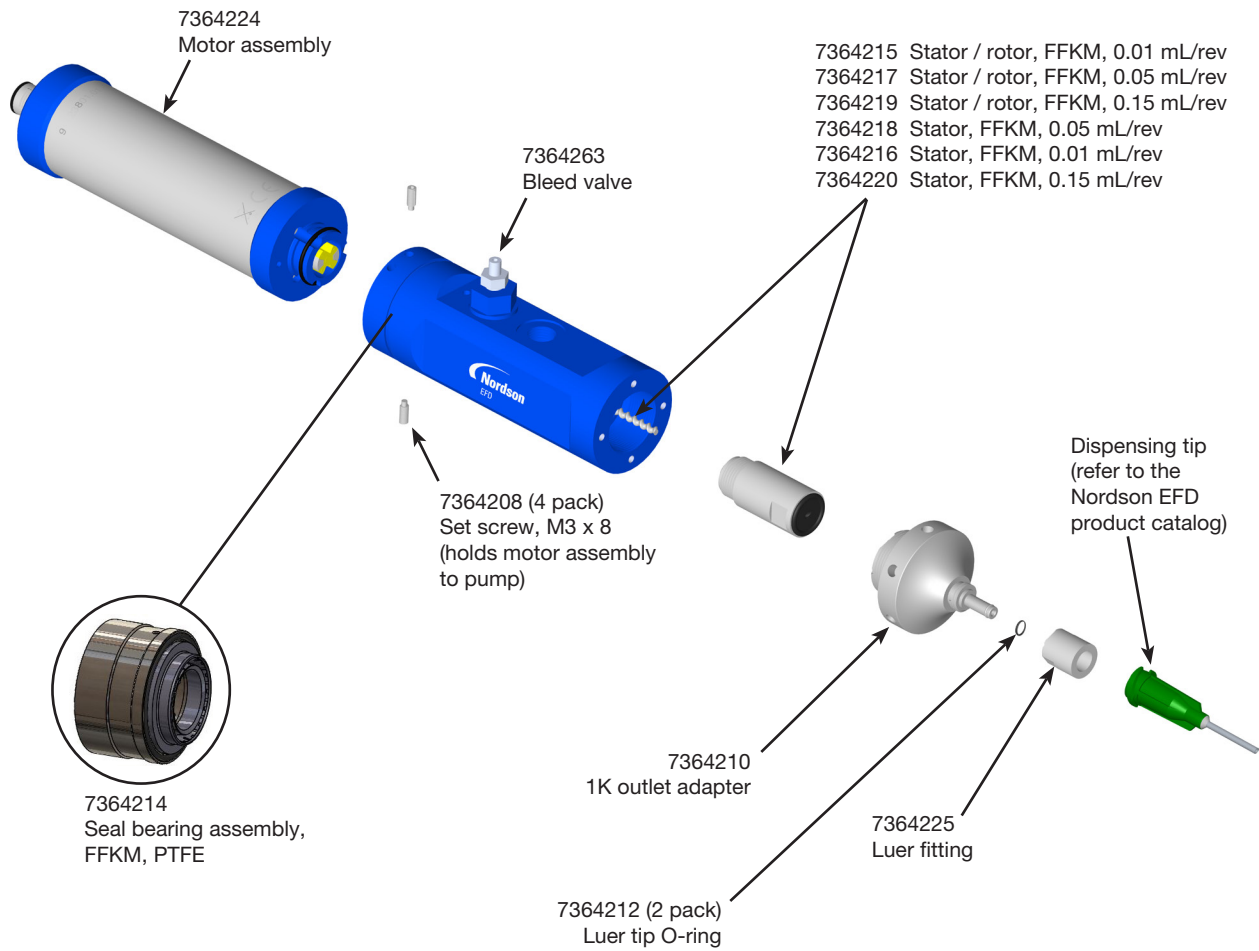

## Troubleshooting

Problem	Possible Cause	Corrective Action
No fluid flow	Dispense tip clogged	Replace the dispense tip.
	Loose or disconnected pump motor cable	Check the motor cable connection. Tighten if needed.
	Fluid supply low or empty	<div style="background-color: #e1f5fe; padding: 5px;"><b>⚠ CAUTION</b></div> Risk of equipment damage. <b>Do not operate the 797PCP without fluid.</b> Excessive friction of dry components can damage the pump.  Check the fluid supply.
	Fluid pressure too low	Increase the fluid pressure.
Inconsistent deposit size	Fluid dried or cured	Replace the fluid supply with fresh fluid.
	Fluid pressure fluctuating	Ensure that the fluid pressure remains constant.
	Dispense time too short	Increase the dispense time. Refer to the controller manual for information on controlling the pump.
	Trapped air in the dispensing tip or fluid supply	Purge the system. Refer to “Purge Through the Tip” on page 15.
Skipped deposits	Intermittent pump motor signal	Check the pump motor cable and motor assembly; tighten connections or replace components as needed.
	Trapped air in the dispensing tip or fluid supply	Purge the system. Refer to “Purge Through the Tip” on page 15.
Fluid drools after pump is turned off	Trapped air in the dispensing tip or fluid supply	Purge the system. Refer to “Purge Through the Tip” on page 15.
	Suck-back setting too low	Adjust the suck-back setting (Reverse %). Refer to the controller manual.

## NORDSON EFD ONE YEAR LIMITED WARRANTY

This Nordson EFD product is warranted for one year from the date of purchase to be free from defects in material and workmanship (but not against damage caused by misuse, abrasion, corrosion, negligence, accident, faulty installation, or by dispensing material incompatible with equipment) when the equipment is installed and operated in accordance with factory recommendations and instructions.

Nordson EFD will repair or replace free of charge any defective part upon authorized return of the part prepaid to our factory during the warranty period. The only exceptions are those parts which normally wear and must be replaced routinely, such as, but not limited to, valve diaphragms, seals, valve heads, needles, and nozzles.

In no event shall any liability or obligation of Nordson EFD arising from this warranty exceed the purchase price of the equipment.

Before operation, the user shall determine the suitability of this product for its intended use, and the user assumes all risk and liability whatsoever in connection therewith. Nordson EFD makes no warranty of merchantability or fitness for a particular purpose. In no event shall Nordson EFD be liable for incidental or consequential damages.

This warranty is valid only when oil-free, clean, dry, filtered air is used, where applicable.

To register your equipment, please go to [www.nordsonefd.com/warranty/valves/one](http://www.nordsonefd.com/warranty/valves/one)



For Nordson EFD sales and service in over 40 countries, contact Nordson EFD or go to [www.nordsonefd.com](http://www.nordsonefd.com).

**Global**

800-556-3484; +1-401-431-7000  
[info@nordsonefd.com](mailto:info@nordsonefd.com)

**Europe**

+44 (0) 1582 666334  
[uk@nordsonefd.com](mailto:uk@nordsonefd.com)

**Asia**

China: +86 (21) 3866 9006; [china@nordsonefd.com](mailto:china@nordsonefd.com)  
India: +91 80 4021 3600; [india@nordsonefd.com](mailto:india@nordsonefd.com)  
Japan: +81 03 5762 2760; [japan@nordsonefd.com](mailto:japan@nordsonefd.com)  
Korea: +82-31-736-8321; [korea@nordsonefd.com](mailto:korea@nordsonefd.com)  
SEAsia: +65 6796 9522; [sin-mal@nordsonefd.com](mailto:sin-mal@nordsonefd.com)

The Wave Design is a trademark of Nordson Corporation.  
©2019 Nordson Corporation 7364291 v101619